

1 Installation can be done with screws or silicone glue. The correct application must be carefully identified according to the wall material.

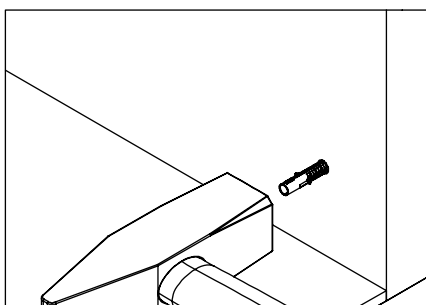

2 Place the correct dowels according to the wall material into the drilled holes.

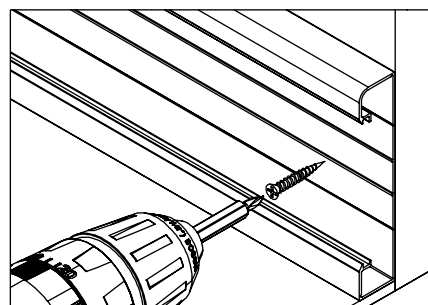

3 Screw the wall fixation parts to the places that are drilled at 50cm intervals.

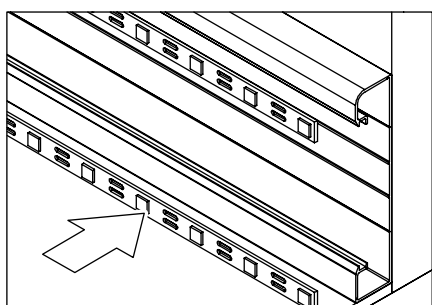

4 Insert the LED strips into the slots at the top and bottom of the profile.

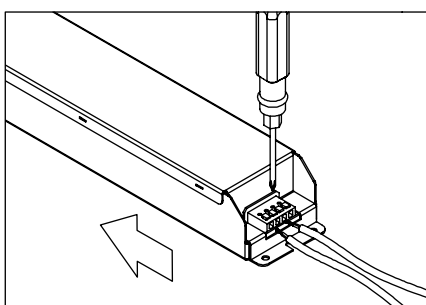

5 Connect the LED strips and the driver and the driver to the mains. Cables can be carried within the profiles for multi-drive connections. Consult local electricians to obtain accurate results.

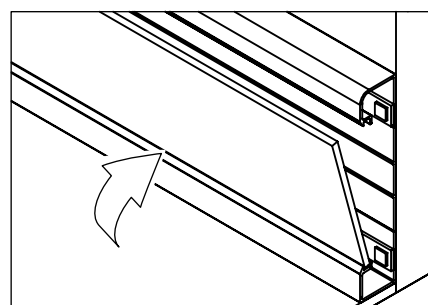

6 Press the diffuser against the back plate until it clicks into place.

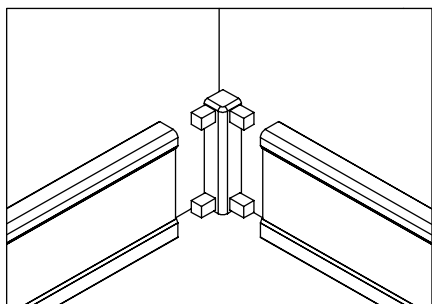

7 Apply adhesive to the internal corners to secure them in position.

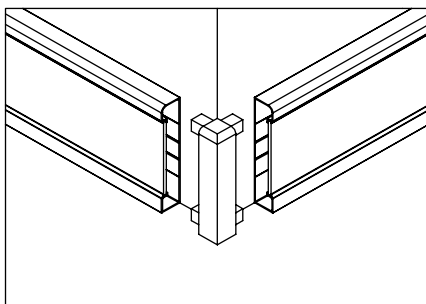

8 Apply adhesive to the external corners to secure them in position.

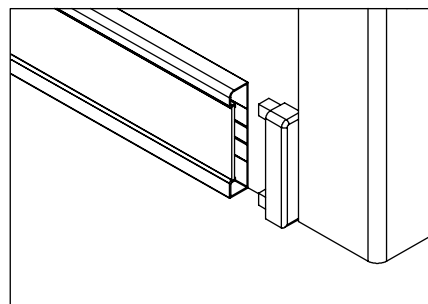

9 Apply adhesive to the ending parts to secure them in position.

LED STRIP CUTTING & EXTENDING

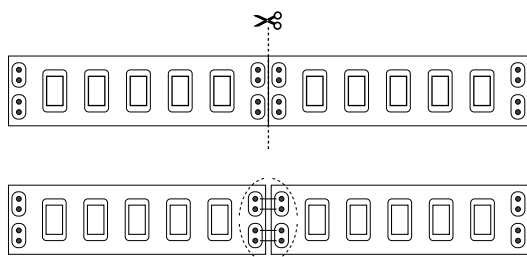

For correct operation of the LED Strip, cut only from the location indicated in the diagram.

To avoid disconnection between the LED Strip, solder only at the location indicated in the sample drawing.

LED STRIP WIRING DIAGRAM

